

RIGID GALVANIZED (RGC)
MULTI-CELL RACEWAY

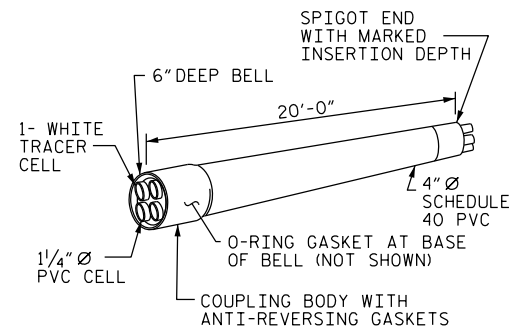

SCHEDULE 40 PVC
MULTI-CELL RACEWAY

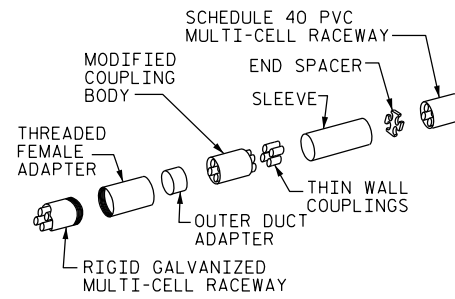

TRANSITION ADAPTER

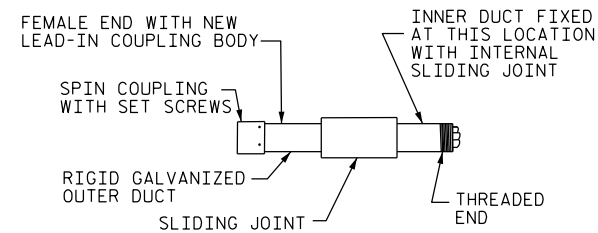

EXPANSION JOINT FITTING

NOTES

THE CONTRACTOR SHALL BE RESPONSIBLE FOR DETERMINING THE TOTAL QUANTITY OF CONDUIT NEEDED TO COMPLETE THE WORK AND THAT THE CONDUIT(S) ARE PLACED AT THE NOTED DIMENSION AND ABOVE THE BOTTOM OF THE GIRDER.

THE INSTALLATION OF THE CONDUIT SYSTEM SHALL BE PAID FOR AS LUMP SUM. THE PRICE SHALL INCLUDE ALL CONDUIT, HANGERS, STABILIZERS, EXPANSION JOINTS, CONCRETE INSERTS, PVC SLEEVES AND ALL NECESSARY HARDWARE TO COMPLETE THE WORK.

THE CONTRACTOR SHALL FIELD VERIFY THAT THE CONDUIT SYSTEM IS NOT IN CONFLICT WITH THE GUARDRAIL POSTS.

SEE DETAIL "C" FOR HANGER ASSEMBLY INSTALLATION.

INSTALL SLEEVES PARALLEL TO GIRDERS. SEE DETAIL "B" FOR SLEEVE INSTALLATION.

PROVIDE TRANSITION ADAPTOR (AND EXPANSION JOINT) FOR CONDUIT AT END BENT 1 (AND END BENT 2).

INSTALL STABILIZER'S MIDWAY BETWEEN DECK EXPANSION JOINTS. STABILIZER CAN NOT BE USED INSTEAD OF A HANGER ASSEMBLY.

INSTALL EXPANSION JOINTS AT BENT #, BENT #, BENT #, AND BENT #.

THE CONCRETE SCREW INSERT SHALL HAVE A ROD SIZE OF 5/8" AND A PULL FORCE OF 1260 lbs.

FOR ELECTRICAL CONDUIT SYSTEM FOR SIGNALS, SEE SPECIAL PROVISIONS.

DETAIL "A"

TERMINATION OF CONDUIT AT WING WALL

DETAIL "B"

PVC SLEEVE INSTALLATION & RGC/PVC ADAPTOR AT BACKWALL.

DETAIL "C"
HANGER ASSEMBLY

CONDUIT LAYOUT

DETAIL "E"
STABILIZER

PROJECT NO. _____

_____ COUNTY

STATION: _____

SHEET _ OF _

VIEW "A-A"

VIEW "B-B"

VIEW "C-C"

DETAIL "F"
DEFLECTION COUPLER

STATE OF NORTH CAROLINA
DEPARTMENT OF TRANSPORTATION
RALEIGH
STANDARD
ELECTRICAL CONDUIT
SYSTEM FOR SIGNALS

ASSEMBLED BY :	DATE :
CHECKED BY :	DATE :
DRAWN BY : RWW 2-4-03	REV. 5/1/06 TLA/GM
CHECKED BY : DBM 2-4-03	REV. 10/1/11 MAA/GM
	REV. 12/17 MAA/THC

ELECTRIC CONDUIT DETAILS

NO.	BY:	DATE:	REVISIONS			SHEET NO.
			NO.	BY:	DATE:	
1			3			TOTAL SHEETS
2			4			

DOCUMENT NOT CONSIDERED
FINAL UNLESS ALL
SIGNATURES COMPLETED